

REVISIONS			
REV	DESCRIPTION	DATE	APPROVED
1	UPDATED FOR RFI AND VDE CHG'S	6/92	LT/JWS
2	UPDATED FOR RFI	9/92	LT/JWS
3	ADDED NOTES	10/92	LT/JWS
4	CHG'S PER ECO # 0-0598	1/93	LT/JWS
5	CHG'D Q1, Q2 TO APT5020 AND ADDED FUSE TBL. PER #SC99-007	10-12-99	CZ/DG/TJO

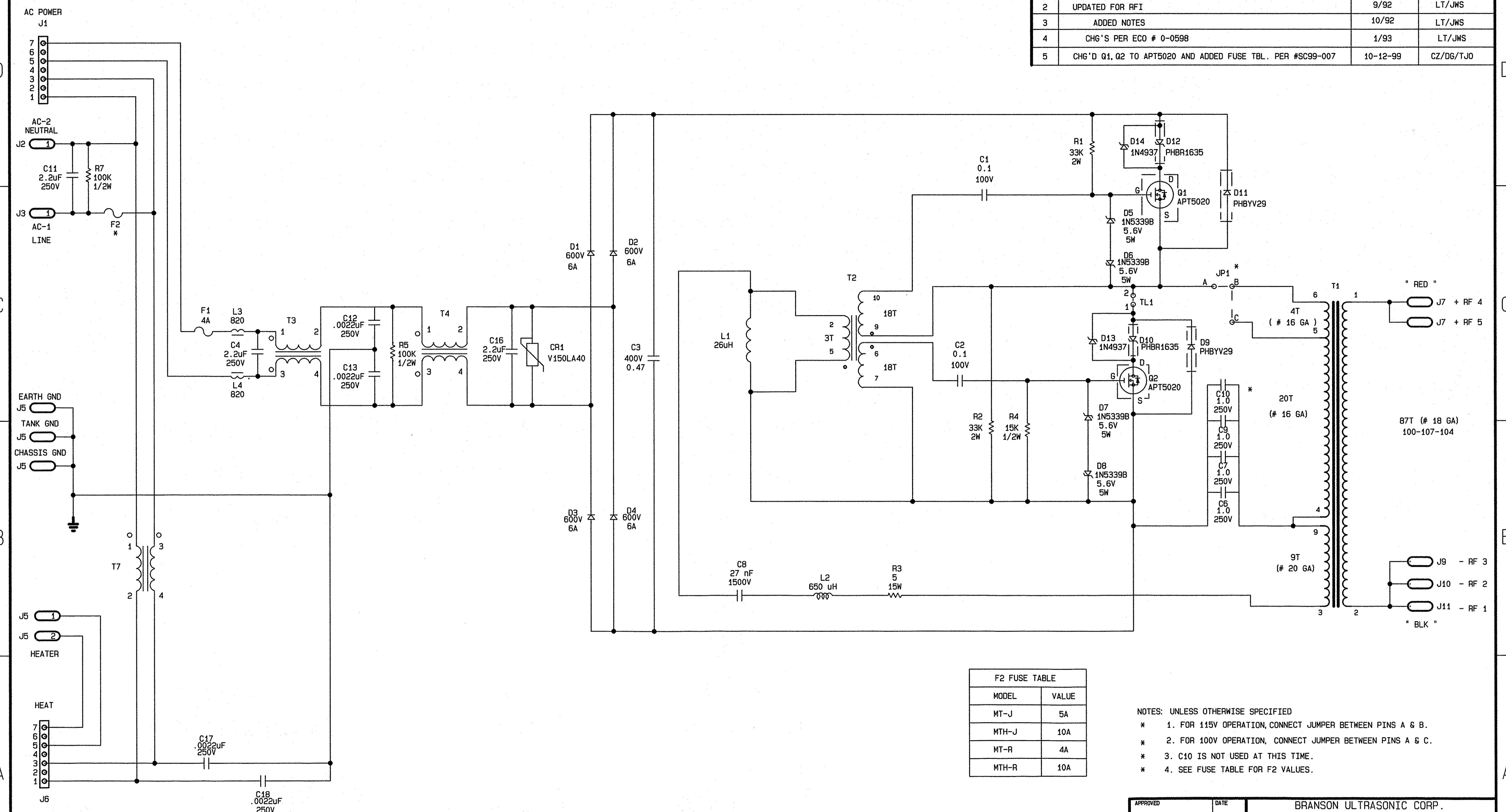

MODEL	VALUE
MT-J	5A
MTH-J	10A
MT-R	4A
MTH-R	10A

- NOTES: UNLESS OTHERWISE SPECIFIED
- * 1. FOR 115V OPERATION, CONNECT JUMPER BETWEEN PINS A & B.
 - * 2. FOR 100V OPERATION, CONNECT JUMPER BETWEEN PINS A & C.
 - * 3. C10 IS NOT USED AT THIS TIME.
 - * 4. SEE FUSE TABLE FOR F2 VALUES.

APPROVED	DATE	BRANSON ULTRASONIC CORP.		
DRAWN	DATE	41 EAGLE RD. DANBURY, CT. 06813-1961 (203) 796-0400		
DES.	DATE	TITLE		
CHECKED	DATE	8210 -MT/MTH -JR		
PRJ. ENG	DATE	USED ON	SIZE	DWG. NO.
		8210/8510/SM85	D	913-242-179
		SCALE	NONE	REV 5
				SHEET 1 OF 1